



AL-5

Capacitor Discharge
Aluminum Dent Pulling System



Instruction Manual

MNL-AL-5-2.0





■ About Pro Spot

Pro Spot International, Inc., based in Carlsbad, California, manufactures resistance spot welding equipment specializing in applications for the collision repair industry. The company began in 1986. The company owns and manages an on site machine shop, research & development department, a fabrication facility and production lines for the various welders

Pro Spot International exports its products worldwide, export sales are managed through our headquarter office. The company owns numerous patents for our ingenious application tools, machines, and procedures.

■ Pro Spot training and services

Pro Spot Distributors and Sub-Distributors are carefully selected and are well trained in the collision repair industry. We offer technical and service education at our world wide training facilities at regular intervals so your local distributor will always be up to date and able to pass on the latest in spot welding technology to our customers.

Customer service is an important part of any investment and our distributors and sub-distributors will be there to support your technical and service needs. We have a great customer service record, we tend to keep it that way.



Pro Spot is certified by CASE and a member of the ICAR Industry Training Alliance

■ Contact Information

Pro Spot International, Inc. U.S.A.
www.prospot.com

5932 Sea Otter Pl.
Carlsbad, CA 92010

Phone: +1 760-407-1414
Toll free (US only): 877- PRO SPOT
Fax: 760-407-1421
E-Mail: info@prospot.com

Table of Contents

1.0 INTRODUCTION	4
2.0 SAFETY & ENVIRONMENTAL SPECIFICATIONS	5
3.0 GETTING FAMILIAR WITH YOUR WELDER - READ BEFORE USING	7
4.0 GETTING FAMILIAR WITH YOUR GUN	8
5.0 CREATING A PROPER GROUND	9
6.0 ADJUSTING THE ELECTRODE PRESSURE KNOB	9
7.0 GETTING READY TO WELD	10
8.0 WELDING INSTRUCTIONS	11
9.0 IDENTIFYING COMMON ISSUES	12
10.0 PRO PULL ASSEMBLY INSTRUCTIONS	13
11.0 WELDER PARTS LIST	16
12.0 WELDER GUN PARTS LIST	18
WARRANTY REGISTRATION	19
WARRANTY	20

Congratulations on acquiring your new PRO SPOT AL-5 Welder!

Team Pro Spot looks forward to supporting you.

The following information will be needed when you call Pro Spot.

* MODEL TYPE: AL-5

* SERIAL NO:

The serial number is located on the back of the unit.

For parts or service contact your local distributor,

Local Number: _____

or in the U.S. call: Toll Free: 1-877 PRO SPOT or 1-760-407-1414

for a customer service representative.

Visit Pro Spot On-Line: www.prospot.com

Email: info@prospot.com

NOTE: You can now order parts online at prospot.com/store/

Pro Spot's AL-5 Capacitor Discharge Stud Welder is designed for aluminum dent pulling but can also be used with steel studs for welding to UHSS panels with no or very little heat applied to the panels. The welder is very easy to use and is controlled by one knob to adjust weld power. The welder auto detects the line voltage 110/240 VAC.

NOTE: This instruction manual provides advice as well as instructions for installation, operation, maintenance and troubleshooting.



IMPORTANT! Read this manual carefully to become familiar with the proper operation of the welder. Do not neglect to do this as improper handling may result in personal injury and damage to the equipment.



IMPORTANT! Lisez ce Mode d'Emploi attentivement afin de vous familiariser avec le bon fonctionnement du soudeur. Ne négligez pas de le faire puisque une mauvaise manipulation peut conduire aux blessures et dommages à l'équipement.

The drawings in this manual are presented for illustrative purposes only and do not necessarily show the design of the equipment available on the market at any given time. The equipment is intended for use in accordance with current trade practice and appropriate safety regulations. The equipment illustrated in the manual may be changed without prior notice.

The contents in this publication can be changed without prior notice.

This publication contains information that is protected by copyright laws. No part of this publication may be reproduced, stored in a system for information retrieval or be transmitted in any form, in any manner without Pro Spot International, Inc.'s written consent.

Conformity with directives and standards: AL-5 complies with UL, EN, and CE Standards.

2.0 Safety & Environmental Specifications

The AL-5 Stud welder is designed for indoor use - Protection Degree IP21.

The AL-5 Stud welder is designed to operate from -10° C to 40° C.

The unit may be stored and transported in an ambient temperature from -20° C to +55° C. The unit can be operated at 95% Relative Humidity (RH). For operation above 1000m consult the manufacturer. Do not operate the unit on a slope of more than 10°. The unit meets the requirements of IEC|EN60974-1 2005 third edition and UL60974-1 2nd edition. E.M.C. classification CISPR 11, FCC 15.107(b), Class A.

NOTE: Heating tests were performed at room ambient temperature and the duty cycle at 40° C has been determined by simulation.

2.1 General

The AL-5 stud welder has been designed and is tested to meet strict safety requirements. Please read the following instructions carefully before operating the AL-5 and refer to them as needed to ensure the continued safe operation of the welder.

Information provided in this manual describes the suggested best working practices and should in no way take precedence over individual responsibilities or local regulations.

The AL-5 Stud Welder is designed to comply with all applicable safety regulations for this type of equipment. During operation, it is always each individual's responsibility to consider:

- Their own and other's personal safety.
- The safety of the welder through correct use of the equipment in accordance with the descriptions and instructions provided in this manual.

By observing and following the safety precautions, users of the AL-5 will ensure safer working conditions for themselves and their fellow workers.

2.2 Warnings and Important Notices

The following types of safety signs are used on the equipment and in Pro Spot's Instruction Manuals:

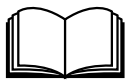

Caution.
Read instruction manual.



Attention!
Lire Mode d'Emploi.



Prohibited.
Prohibits behaviour that can cause injury.



Interdit.
Interdit aux comportements qui peuvent provoquer des blessures.



Command.
Calls for a specific action.



Commande.
Appelle à une action spécifique.

Warning.
Notice of personal injury risk and or damage to equipment.

Avertissement.
Avis de risque de blessure personnelle et / ou d'endommager l'équipement.



Warning.
Some parts of the welder may become hot after prolonged use.



Avertissement.
Certaines parties du soudeur peuvent devenir chaudes après une utilisation prolongée.

The following warnings and important notices are used in the instruction manual:

	WARNING! Do not operate or place the welder near water, in wet locations or outdoors. Risk for injuries or damage to the welder.		ATTENTION! Ne pas faire fonctionner le soudeur près de l'eau, en voie humide, ou à l'extérieur. Risque de blessures ou de dommages au soudeur.
	WARNING! Do not place the welder on unstable or uneven ground. The welder might tip causing personal injuries or serious damage to the welder.		ATTENTION! Ne placez pas le soudeur sur un sol instable ou irrégulière. Le soudeur peut basculer causant des lésions corporelles ou des dommages graves au soudeur.
	WARNING! All electrical connections must be made by a qualified electrician. Risk for electrical shock.		ATTENTION! Toutes les connexions électriques doivent être faites par un électricien qualifié. Risque de choc électrique.
	WARNING! Loose cables and hoses present tripping risks. Risk for injuries.		ATTENTION! Câbles et tuyaux lâches présentent des risques de déclenchement. Risque de blessures
	WARNING! Make sure to use welding goggles when stud welding. The sparks and UV light might otherwise injure the eyes.		ATTENTION! Veuillez utiliser des lunettes de soudeur sur goujon. Les étincelles et lumière UV pourraient autrement blesser les yeux.
	WARNING! Sparks from welding could start a fire. Risk for injuries.		ATTENTION! Étincelles de soudure pourrait provoquer un incendie. Risque de blessures.
	WARNING! Risk for damage to materials close to the weld, e.g to glass or textiles.		ATTENTION! Risque de dommages aux matériaux à proximité de la soudure, par exemple verre ou textiles.
	WARNING! Do not use around combustible gas.		ATTENTION! Ne pas utiliser à proximité de gaz combustible.
	WARNING! All service and maintenance must be carried out by Pro Spot service personnel and service support. Risk for electrical shock.		ATTENTION! Tout le service et l'entretien doivent être effectués par personnel et soutien de service Pro Spot. Risque de choc électrique.
	WARNING! If you are a Pro Spot employee unplug the welder from the wall outlet before servicing, cleaning, or maintenance. Risk for electrical shock.		ATTENTION! Si vous êtes un spot employés Pro débranchez le soudeur de la prise murale avant de l'entretien, le nettoyage ou l'entretien. risque pour choc électrique.
	IMPORTANT! The AL-5 welder may only be used by qualified personnel. The user of the welder must have knowledge of stud welding and of alignment of collision-damaged vehicles.		IMPORTANT! Le soudeur AL-5 peut seulement être utilisé par personnel qualifié. L'utilisateur du soudeur doit avoir une connaissance de soudage par points et l'alignement des véhicules endommagés par collisions.
	WARNING! Always use in well ventilated area.		ATTENTION! Toujours utiliser dans un endroit bien ventilé



Front Panel Zoom



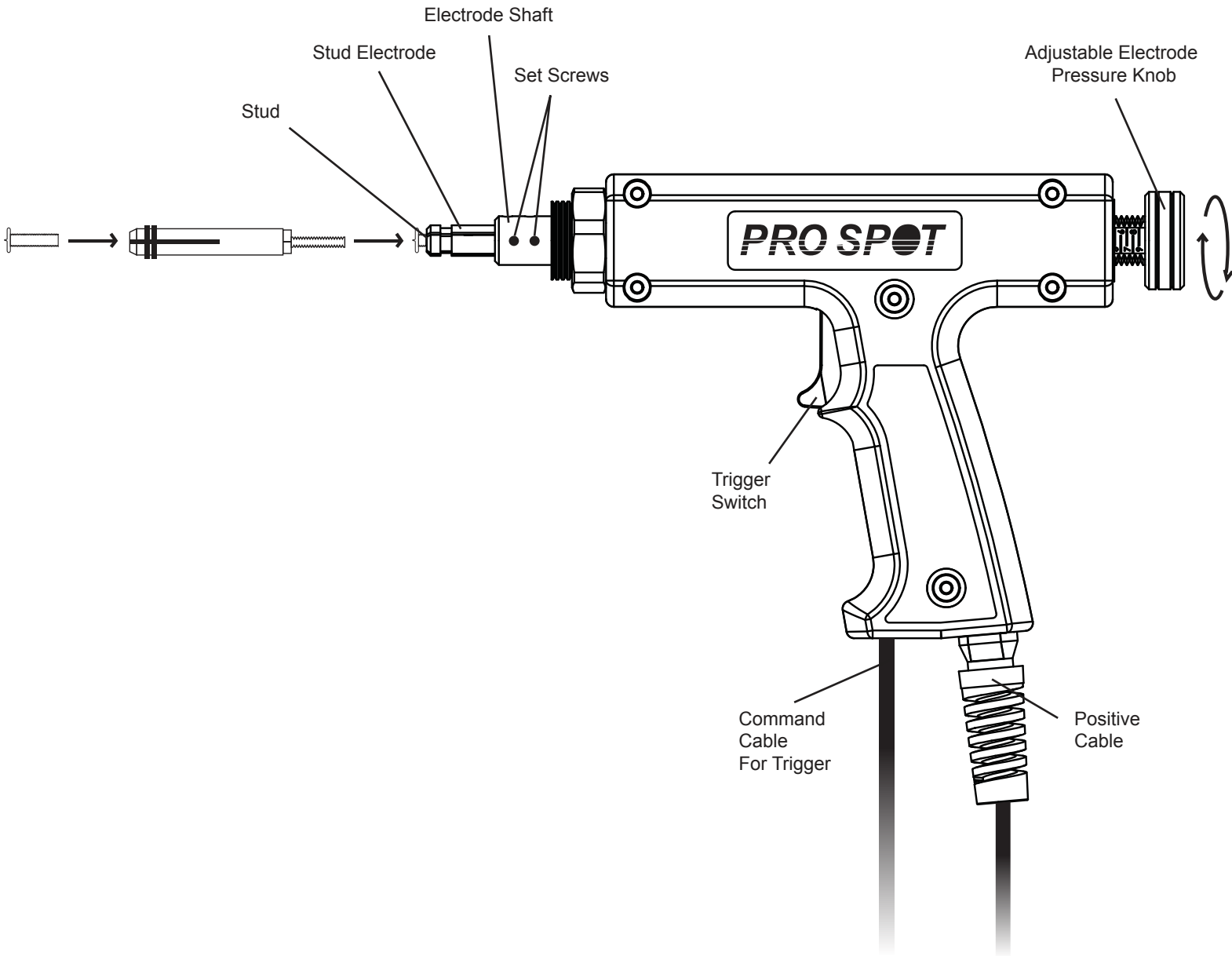

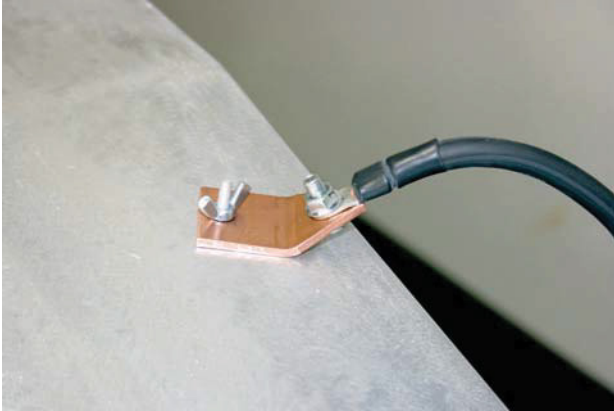

Ground Plate

Clean surface, weld a stud using the AL-5.
 Place the ground plate on top of the stud, use a wing nut or similar to tighten the plate to the panel.
 The closer the ground to the weld location, the better.



Ground Clamp

Alternative method to achieve ground.
 Clean surface on work piece and use ground clamp in this location. The closer the ground to the weld location, the better.

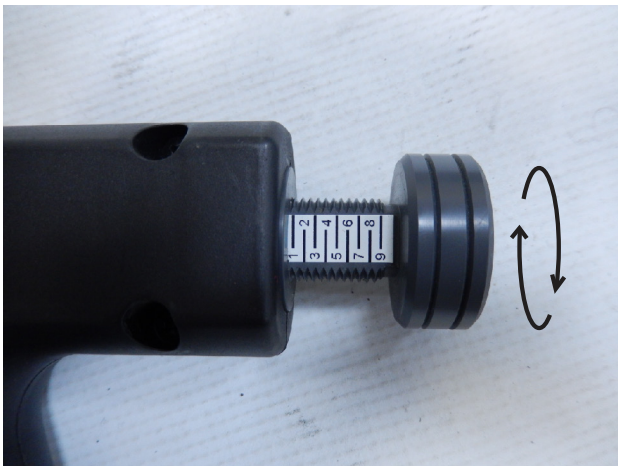

Metal Thickness	Set Knob to:
0.6 - 0.8mm	1 - 2 on Dial
0.8 - 1.0mm	1-3 on Dial
1.0 - 2.5mm	2-4 on Dial

To Weld:

Insert a threaded stud into the matching electrode holder.
Place the gun in a perpendicular 90° position to the weld area.

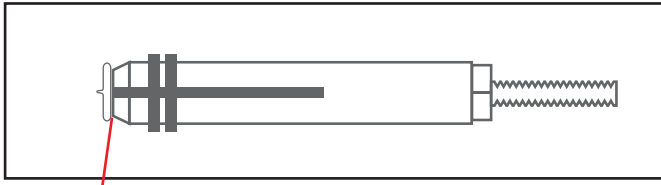

NO GAP Figure 1

In normal operation, the indicator light on the front panel should be as follows:

- OV ○ ○ GRD READY and ON
- OH ○ ○ ● READY lights are illuminated
- ○ ● ON when the welder is on.

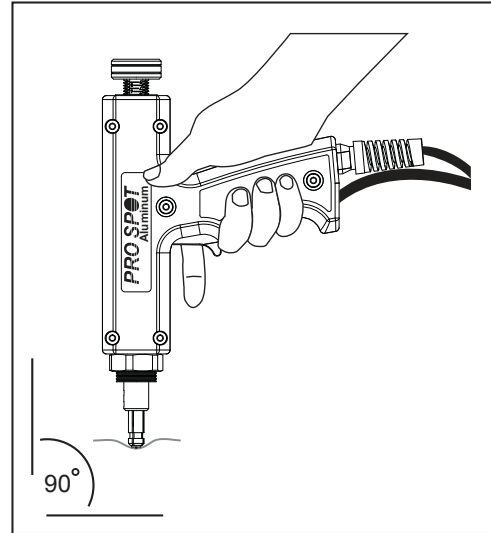
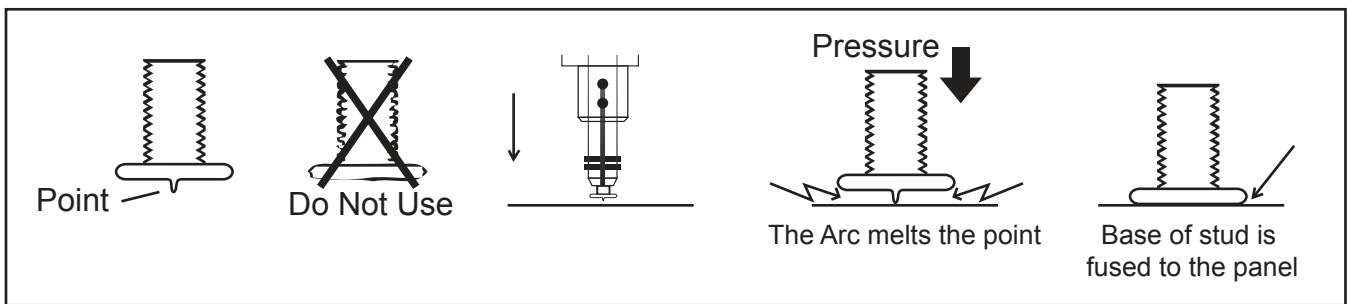

Figure 3

When the stud is placed on the panel, the GRD (ground) Light should turn on and indicate that the ground circuit is complete. If the voltage setting is changed, the ready light will go out until the correct capacitor voltage has been verified. Once the correct capacitor voltage has been verified, the light will turn on again.

The point on the stud creates an arc and the pressure on the stud collapses the point and melts the base of the stud to the panel. All of this occurs in milliseconds to create a proper weld, if the time were longer it could damage or blow a hole in the panel.



Setting the Weld Voltage:

Stud Diameter	Set weld knob to:
4mm	60-90
5mm	70-110
6mm	80-130

1.

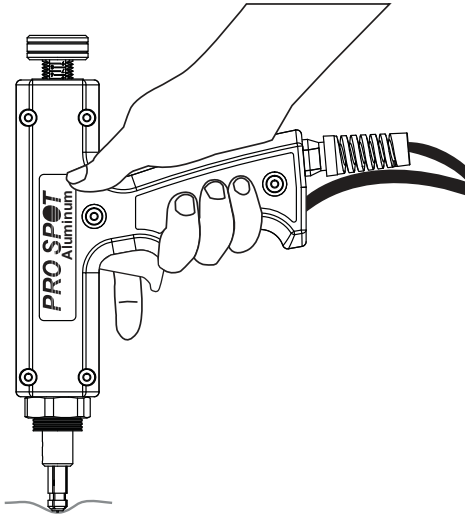

Place stud in desired location.
Do not apply pressure to gun yet.

2.

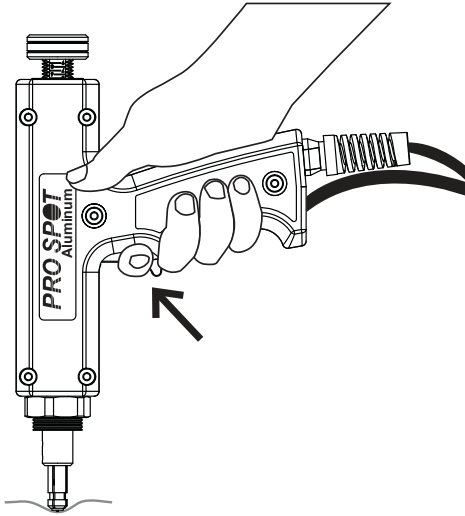

Squeeze and hold trigger.
Again, do not apply pressure to gun yet.

3.

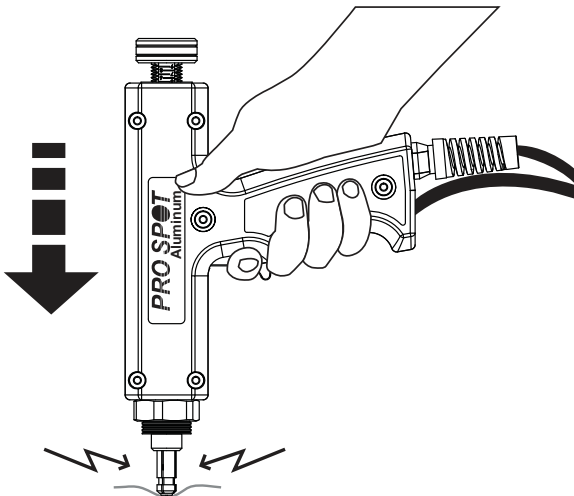

With trigger still squeezed, apply downward pressure until the gun fires and the weld has been made.

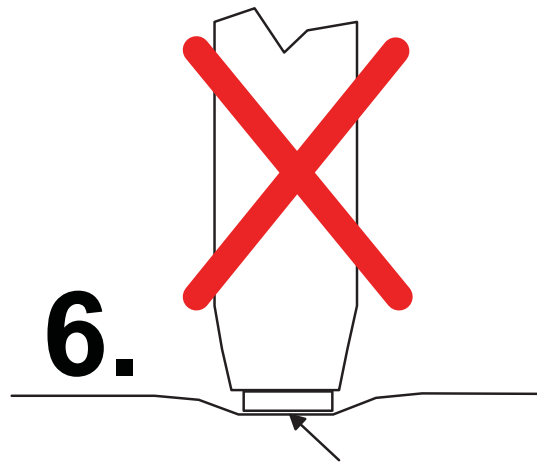
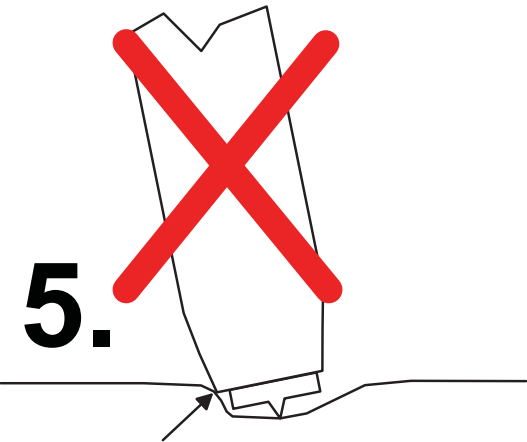
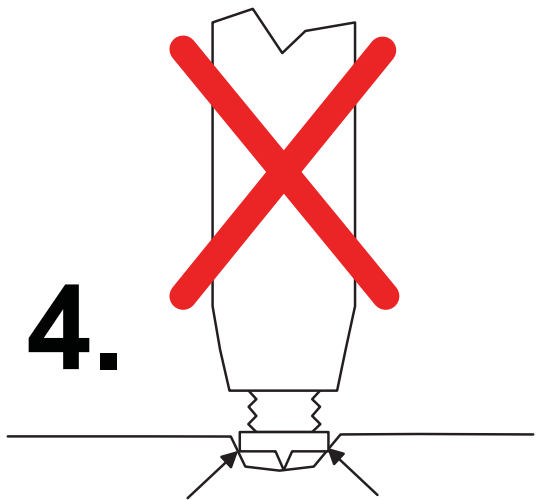
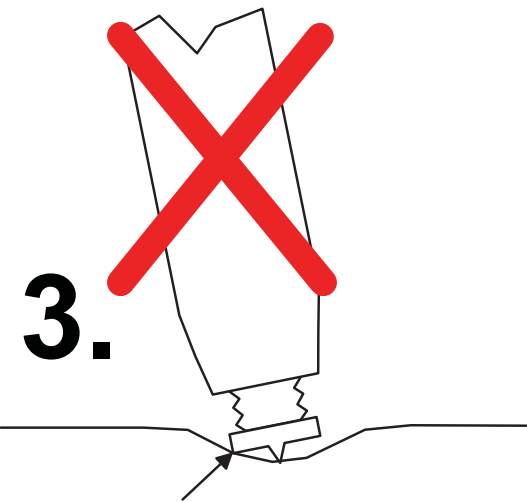
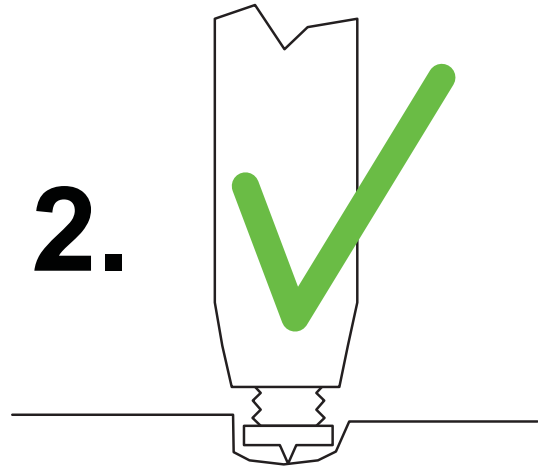
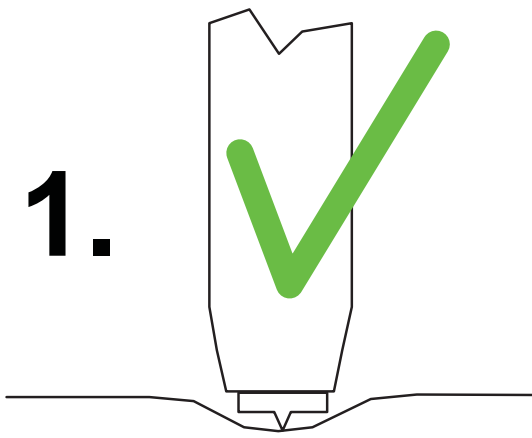

- 1. Make sure the point ONLY touches the surface. GOOD! Stud flush to electrode. GOOD.
- 2. Make sure the point ONLY touches the surface. GOOD! Stud can extend 1/8"(2mm) from electrode. OK.
- 3. Point and head of stud touches the surface. BAD!
- 4. Head of stud touches the surface. BAD!
- 5. Electrode touches surface. BAD!
- 6. No point on stud. BAD! Will not work.

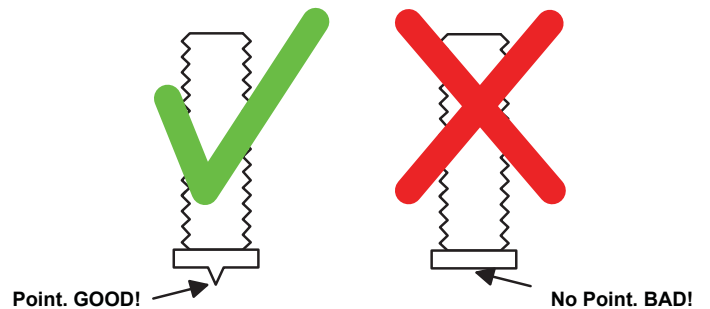

Step 1

Take the shaft assembly apart as seen below

**Step 2**

Remove the Black handle from the Pro Pull gun as seen below.



Step 3

Insert the large shaft into the back of the gun and slide the 90 degree holder into the slot on the large shaft and push down until it goes flat over the handle stud. You might need to back the large nut off to allow that piece to fit into the slot. As seen below.



Step 4

Tighten the large nut to the back of the Pro Pull handle. Hand tightening should be sufficient. As seen below.



Step 5

Slide the threaded rod through the main shaft, put the washer on the threaded rod and put the wing nut on as well. As seen below.



BOM Table

ITEM NO.	PART NUMBER	DESCRIPTION	QTY.
1	90-0154	CHASSIS	1
2	90-0157	PLATE, NEUTRAL	1
3	90-0156	PLATE, POSITIVE	1
4	90-0158	BUSS BAR	1
5	90-0159	PLATE, BACKER	1
6	90-0161	CONTACT SCREW	1
7	90-0161	SPACER, BOX CLAMP	4
8	90-0159	BACKER PLATE	1
9	90-0195	GROUND PLATE	1
10	85-0127	GROUND CLAMP	1
11	CB-500	PCB, CAPACITOR DISCHARGE WELDER	1
12	80-5154	LABEL, FRONT PANEL	1
13	72-0383	CAPACITOR	2
14	77-2275	TRANSFORMER	1
15	82-0101	COOLING FAN 110V	1
16	74-8004	PLUCK DIODE	1
17	63-0031	SOCKET	1
18	52-0119	KNOB	1
19	63-1360	4 PIN CONNECTOR	1
20	78-0469	SWITCH	1
21	52-3503	NYLON SHOULDER WASHER	1
22	52-1903	CORD GRIP	2
23	52-2003	NUT	4
24	51-0133	PANEL NUT, #8	12
25	51-18	STANDOFF, BRASS	2
26	51-04	STANDOFF, PLASTIC	1
27	W1-56	CABLE	2
28	N-90	NUT, BRASS	2
29	N-96	FLANGE NUT 1/4-20	2
30	S-186	M3 X 8 SHCS BLACK	4
31	S-36	PHMS 1/4-20 X .5	2
32	63-107	POWER INPUT	1
33	N19	M3 NIP	1
34	72-9999	CAMP 74mmt CAPACITOR	2
35	52-8540	RUBBER FOOT	4
36	W1-15	1/4-20 X 2" HHCS	10
37	W1-85	1/4-20 X 2" HHCS	4
38	W1-85	#6 INTERNAL TOOTH LOCK WASHER	3
39	S-24	4-32 X 3/8 PHMS	3
40	PR-2000-99B	ROPE DIODE	1
41	S-26	8-32 X 1/2 PHMS	10
42	W-11	#8 LOCK WASHER	6
43	N-07	8-32 NUT	6
44	S-97	M4 X 8 PHMS	4
45	W-06	3/8" EXTERNAL TOOTH WASHER	1
46	W-72	M3 FLAT WASHER	4
47	S-45	4-40 X 1/2 PHMS	1
48	N-16	4-40 NUT WITH EXTERNAL TOOTH WASHER	1
49	S-232	M6 X 12 FLANGE BOLT	6
50	N-03	M6 NUT	2
51	W-76	5/16" EXTERNAL TOOTH WASHER	1
52	S-36	5/16-18 X 3/4 HHCS	1
53	N-36	5/16-18 NUT	1
54	S-176	8-32 X 3/4 PHMS	6
55	PR-2000-80	FAN FILTER ASSEMBLY	1
56	79-0451	CIRCUIT BREAKER	1
57	PR-2000-79	COOLING FAN POWER CORD	1
58	90-0265	INSULATION SHEET	1
59	N-34	1/4-20 HEX LOCK NUT	4
60	N-66	3/4-16 HEX JAM NUT	1
61	W-79	3/4 INTERNAL STAR WASHER	1
62	69-0002	POWER SUPPLY CORD	1

WHERE USED: **AL-5**

SCALE: NONE

PRO SPOT

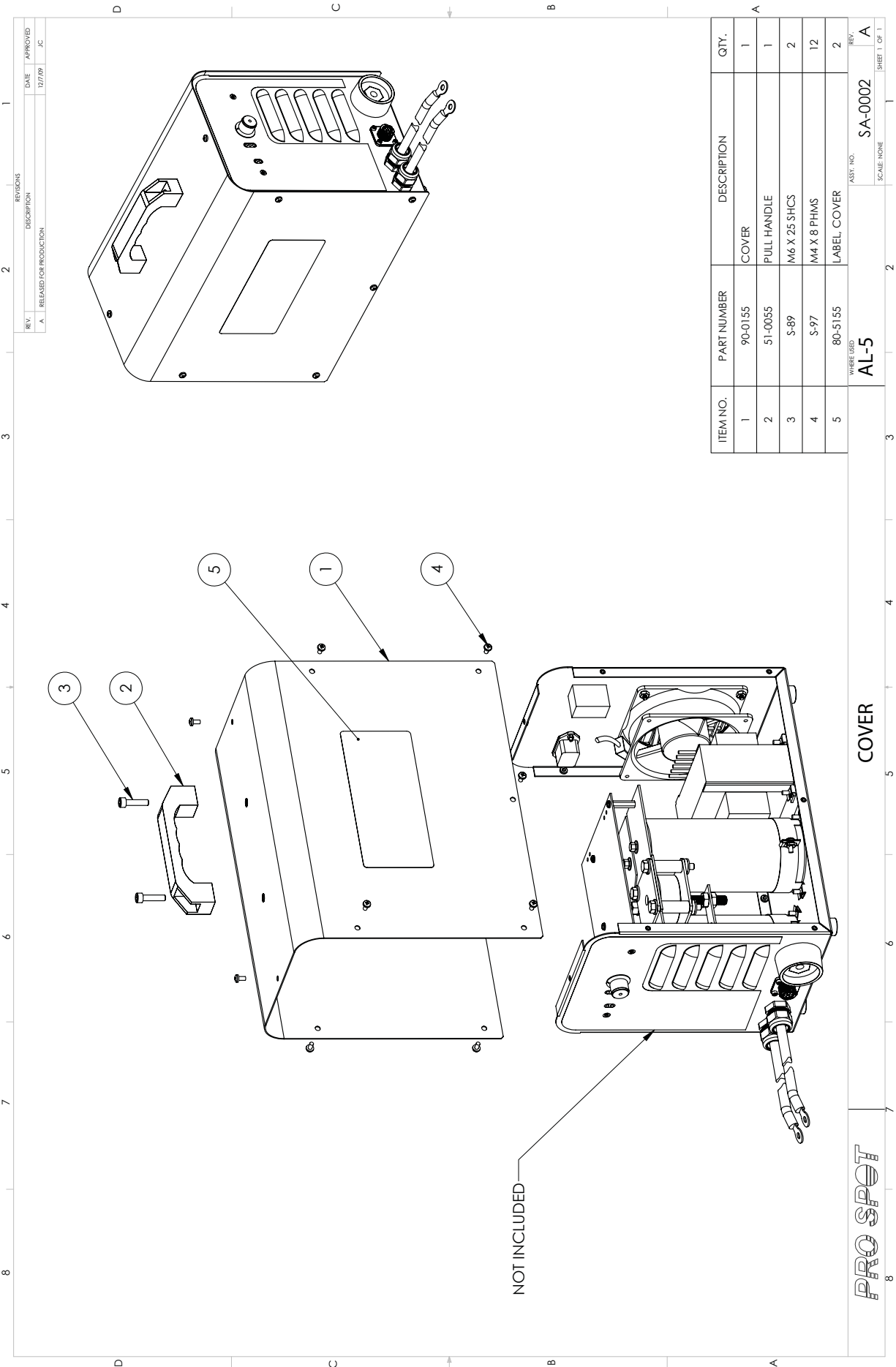

REVISIONS		DATE	APPROVED
REV.	DESCRIPTION		
A.	RELEASED FOR PRODUCTION	12/7/09	JC

ITEM NO.	PART NUMBER	DESCRIPTION	QTY.
1	90-0155	COVER	1
2	51-0055	PULL HANDLE	1
3	S-89	M6 X 25 SHCS	2
4	S-97	M4 X 8 PHMS	12
5	80-5155	LABEL, COVER	2

WHERE USED	ASST. NO.	REV.
AL-5	SA-0002	A
	SCALE: NONE	SHEET 1 OF 1

COVER

PRO SPOT

NOT INCLUDED

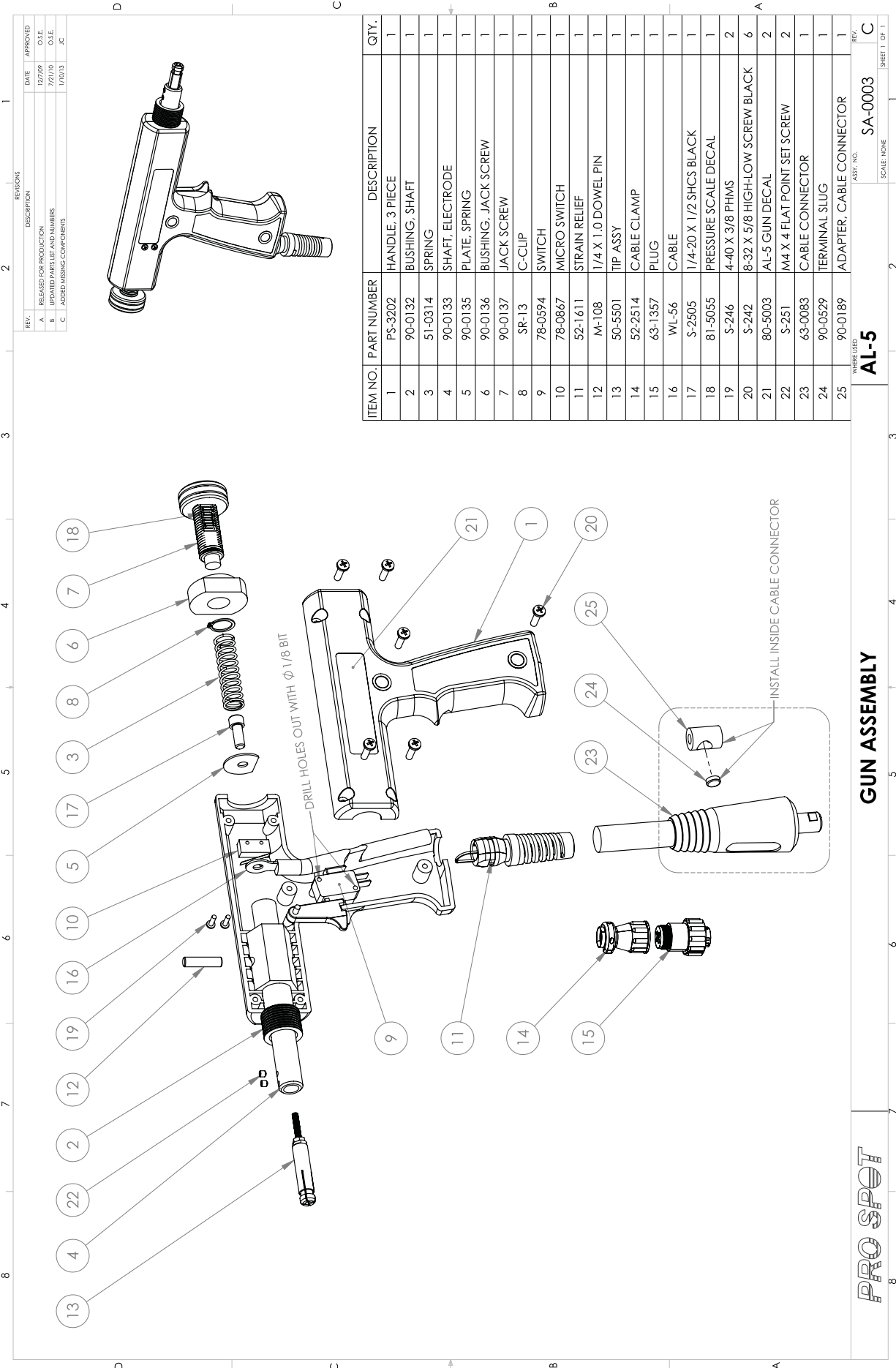

REV.	DESCRIPTION	DATE	APPROVED
A	RELEASED FOR PRODUCTION	12/27/09	C.S.E.
B	UPDATED PARTS LIST AND NUMBERS	7/27/10	C.S.E.
C	ADDED MISSING COMPONENTS	1/16/13	AC

ITEM NO.	PART NUMBER	DESCRIPTION	QTY.
1	PS-3202	HANDLE, 3 PIECE	1
2	90-0132	BUSHING, SHAFT	1
3	51-0314	SPRING	1
4	90-0133	SHAFT, ELECTRODE	1
5	90-0135	PLATE, SPRING	1
6	90-0136	BUSHING, JACK SCREW	1
7	90-0137	JACK SCREW	1
8	SR-13	C-CLIP	1
9	78-0594	SWITCH	1
10	78-0867	MICRO SWITCH	1
11	52-1611	STRAIN RELIEF	1
12	M-108	1/4 X 1.0 DOWEL PIN	1
13	50-5501	TIP ASSY	1
14	52-2514	CABLE CLAMP	1
15	63-1357	PLUG	1
16	WL-56	CABLE	1
17	S-2505	1/4-20 X 1/2 SHCS BLACK	1
18	81-5055	PRESSURE SCALE DECAL	1
19	S-246	4-40 X 3/8 PHMS	2
20	S-242	8-32 X 5/8 HIGH-LOW SCREW BLACK	6
21	80-5003	AL-5 GUN DECAL	2
22	S-251	M4 X 4 FLAT POINT SET SCREW	2
23	63-0083	CABLE CONNECTOR	1
24	90-0529	TERMINAL SLUG	1
25	90-0189	ADAPTER, CABLE CONNECTOR	1

WHERE USED

AL-5

ASST. NO. SA-0003

SCALE: NONE

SHEET 1 OF 1

PRO SPOT

GUN ASSEMBLY



PRO SPOT
QUALITY WELDING SYSTEMS

PRO SPOT INTERNATIONAL INC.
~ AL-5 PRODUCT WARRANTY ~

Pro Spot International Inc., a California corporation, (hereinafter 'Pro Spot') warrants to the original purchaser (hereinafter 'Purchaser') of Pro Spot product(s) referred to in this Purchase Order (hereinafter 'Pro Spot Product') in lieu of all other warrants that Pro Spot International Inc. of Carlsbad, CA shall be free from defects in material and workmanship under intended use and service for a period of one (1) year after delivery of the Pro Spot Product to Purchaser.

Pro Spot's Obligation under this warranty shall be limited to the repair or exchange, at Pro Spot's option of any part or parts, which may prove defective under intended use and service as determined by Pro Spot after said part or parts have been returned to and examined by Pro Spot whose address is 5932 Sea Otter Place, Carlsbad CA 92010. Pro Spot will pay for standard transportation on outgoing warranty related parts. Charges for expedited shipping will be the responsibility of the customer.

This warranty is in lieu of all other warranties, express or implied, including the warranties of merchant ability and fitness for a particular purpose. Pro Spot shall not be liable under expressed or implied warranty for incidental or consequential damages or other obligations or liabilities on the part of the purchaser.

Pro Spot neither assumes nor authorizes any other person to act on behalf of Pro Spot's liability in connection with Pro Spot product.

The above limited warranty does not Apply to damage of Pro Spot product caused by accidents, alterations, negligence, tampering or improper or unreasonable use or failure to provide reasonable maintenance.

Pro Spot makes no warranty whatsoever in respect to accessories or parts not supplied by Pro Spot.

Pro Spot reserves the right to make changes in the design of any product at any time without obligation for retroactive action to the Pro Spot Product. Failure to employ, attach, and or use any and all recommended safety devices (including electrical grounding) and failure to follow and or comply with any recommended safety procedure shall constitute a waiver of this limited warranty. Pro Spot shall not be responsible for any incidental or consequential damages as a result of the aforementioned.

Purchaser is not considered to be a 'consumer' under Magnuson-Moss Warranty Act, but shall be considered a merchant engaged in commerce.

This warranty shall apply within the boundaries of the UNITED STATES and CANADA.

4/12/2012

AL-5 WARRANTY CARD

PRO SPOT INTERNATIONAL, INC.

5932 Sea Otter Place
Carlsbad CA 92010 USA
FAX (760) 407-1421 PHONE (760) 407-1414

FILL OUT AND MAIL OR FAX TO ENSURE WARRANTY REGISTRATION

Company Name:		Address:	
City:		State:	Zip:
Owner/President:			
Phone:		Fax:	
E-Mail:		Web Site:	
Date of Purchase:	Serial No:	Model purchased:	
Purchased from:		Address:	
Comments:			



Pro Spot International, Inc.
5932 Sea Otter Place
Carlsbad, CA 92010

Toll Free: (877) PRO SPOT
Phone: (760) 407-1414
Fax: (760) 407-1421

E-mail: info@prospot.com
Web: www.prospot.com